

CIRCULATING PUMP



www.chinataifu.com

STAR-A/STAR-C CIRCULATING PUMP



STAR-A



STAR-C

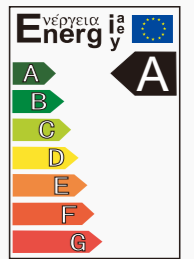

EEL < 0.23

Select



Brass



Cast iron

Pump Features

- Min power: 5W
- Frequency-conversion stator
- Multifunctional electronic component
- Permanent magnetism rotor
- LED display
- Convenient connector
- Erp certificate

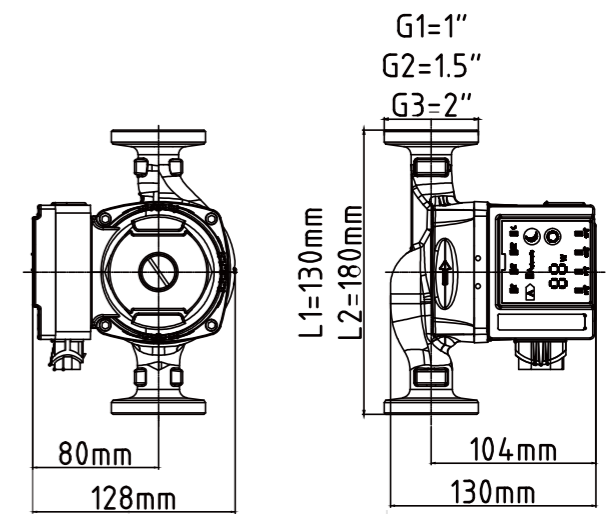
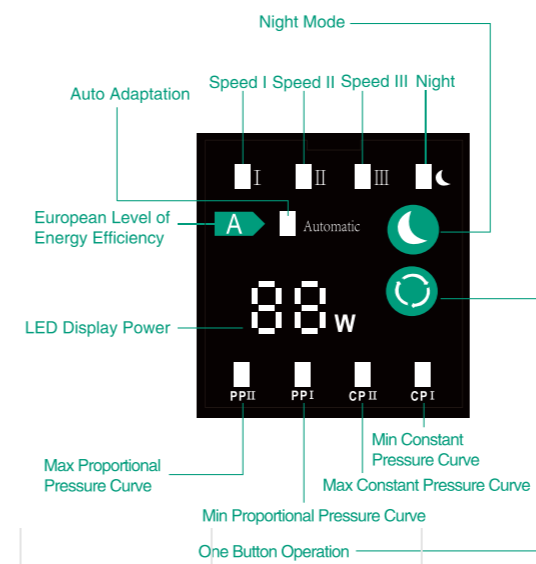

THE REVIVAL OF TAIFU IS SURGING

STAR-A/STAR-C CIRCULATING PUMP

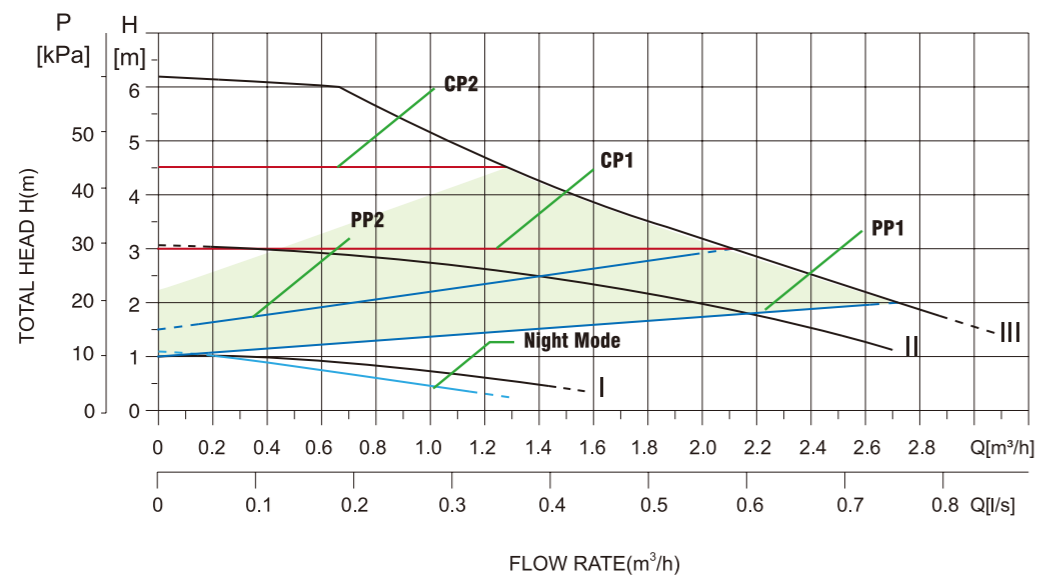
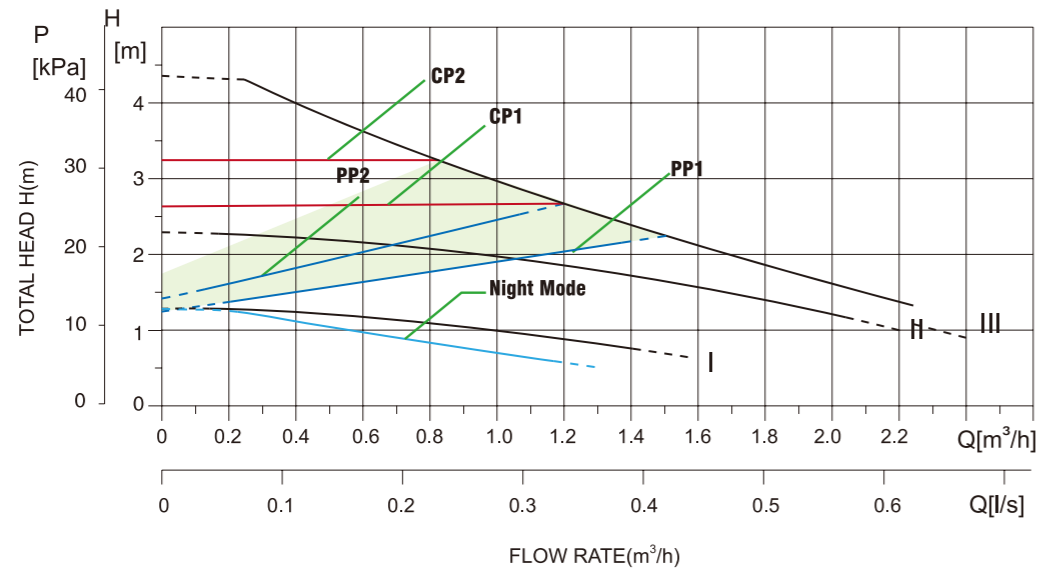

Model	Power (w)	Max Flow Rate (l/min)	Max Head (m)	Inlet/Outlet (In)	
STAR15/4A	STAR15/4C	5-22	40	4	1"X1"
STAR25/4A	STAR25/4C	5-22	40	4	1.5"X1.5"
STAR32/4A	STAR32/4C	5-22	40	4	2"X2"
STAR15/6A	STAR15/6C	5-45	55	6	1"X1"
STAR25/6A	STAR25/6C	5-45	55	6	1.5"X1.5"
STAR32/6A	STAR32/6C	5-45	55	6	2"X2"

NEW STAR CIRCULATING PUMP



EEL < 0.23

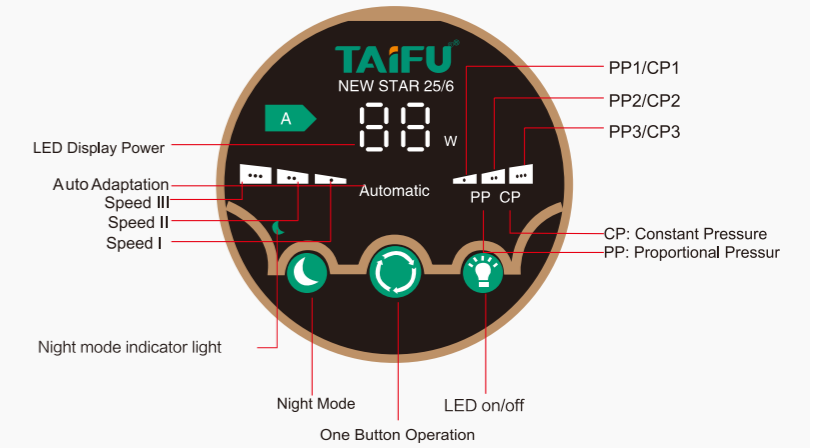

Select



Brass



Cast iron

Pump Features

- Min power: 3W
- Frequency-conversion stator
- Multifunctional electronic component
- Permanent magnetism rotor
- LED display
- Convenient connector
- Erp certificate

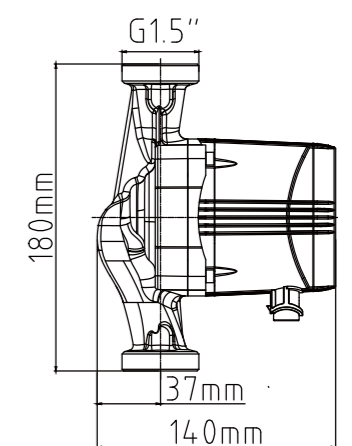
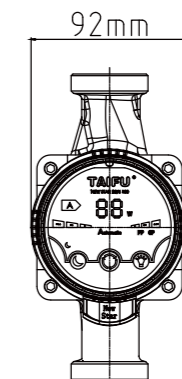

Model	Power (w)	Max Flow Rate (l/min)	Max Head (m)	Inlet/Outlet (In)
NEW STAR25/6	3-35	55	6	1.5"X1.5"
NEW STAR25/4	3-18	40	4	1.5"X1.5"

NEW STAR CIRCULATING PUMP

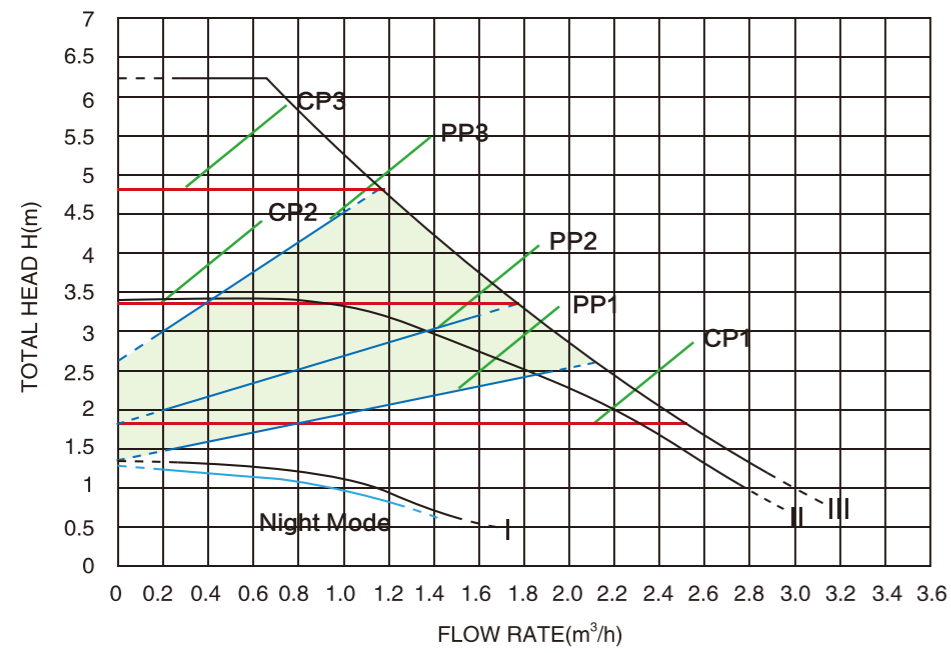
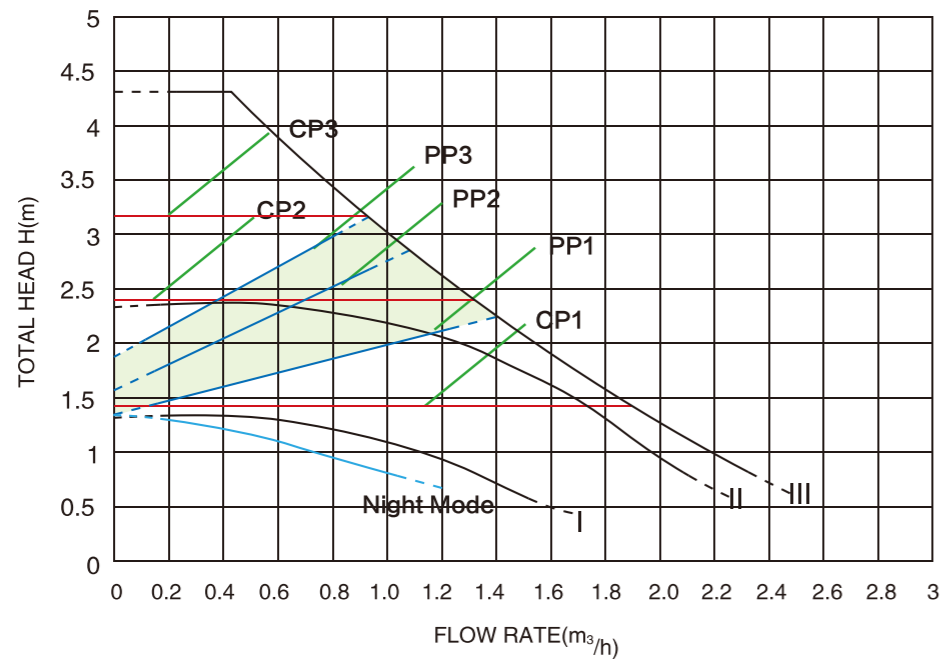

Model	Power (w)	Max Flow Rate (l/min)	Max Head (m)	Inlet/Outlet (In)
NEW STAR25/6	3-35	55	6	1.5"X1.5"
NEW STAR25/4	3-18	40	4	1.5"X1.5"

STAR-F CIRCULATING PUMP



EEl < 0.23

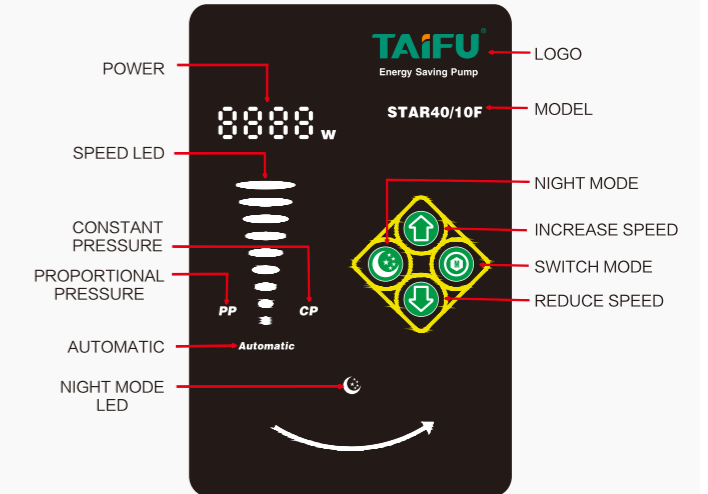

Model	L1	L2	L3	L4	D	DN
STAR40/10F	220	165	388	65	150	40
STAR50/12F	280	165	395	72	165	50
STAR65/15F	340	165	403	80	185	65

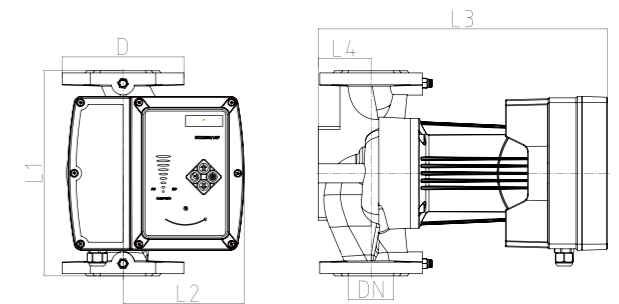

Model	Power (w)	Max Flow Rate (l/min)	Max Head (m)	Inlet/Outlet
STAR40/10F	340	233	10	DN40
STAR50/12F	560	383	12	DN50
STAR65/15F	1300	750	15	DN65

GRS15 GRS25 GRS32 CIRCULATING PUMP



For selection



Castiron



Stainless steel pump body for selection

GRS25/4 GRS25/6

GRS32/8

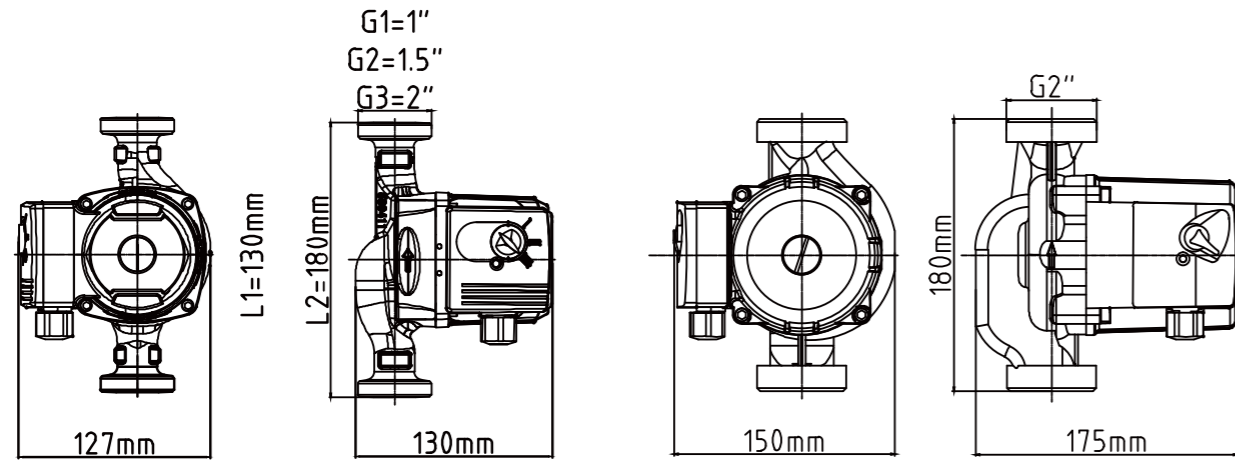

Model	Power (w)	Max Flow Rate (l/min)	Max Head (m)	Inlet/Outlet (In)
GRS15/4	88/60/40	50/35/23	4/3/2	1"X1"
GRS25/4	88/60/40	50/35/23	4/3/2	1.5"X1.5"
GRS32/4	88/60/40	50/35/23	4/3/2	2"X2"
GRS15/6	93/68/40	55/40/30	6/5/4	1"X1"
GRS25/6	93/68/40	55/40/30	6/5/4	1.5"X1.5"
GRS32/6	93/68/40	55/40/30	6/5/4	2"X2"
GRS25/8	100/70/40	40/25/20	8/5/4	1.5"X1.5"
GRS32/8	225/190/125	170/90/30	8/7/4	2"X2"
GRS-SS25/6	93/68/40	55/40/30	6/5/4	1.5"X1.5"

GRS-F/GRS-M CIRCULATING PUMP



Flange



Connector

GRS-F

GRS-M

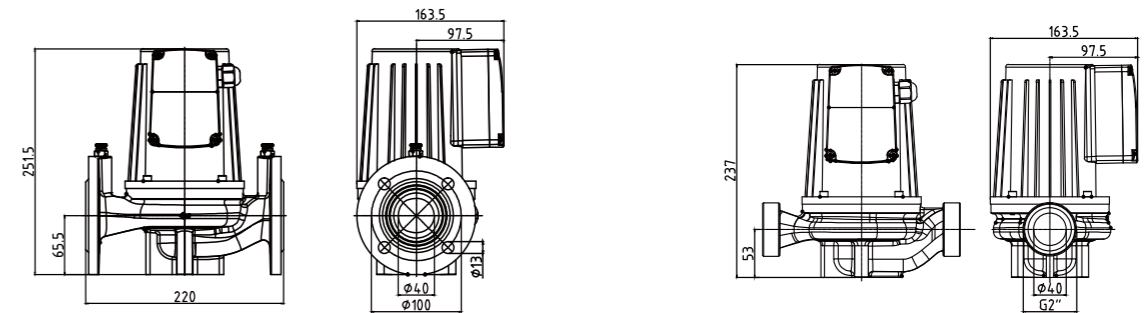

GRS-F

GRS32/12-M

Model(3 phase)	Power (w)	Max Flow Rate (l/min)	Max Head (m)	Inlet/Outlet
GRS40/10F	550	300	10	DN40
GRS40/12F	750	300	12	DN40
GRS50/12F	1100	420	12	DN50
GRS65/11F	1500	750	11	DN65

Model (single phase)	Power (w)	Max Flow Rate (l/min)	Max Head (m)	Inlet/Outlet (In)
GRS32/12-M	370	135	12	2"x2"

GRS F-M CIRCULATING PUMP



Flange



GRS-Z CIRCULATING PUMP



Select



Brass



Cast iron

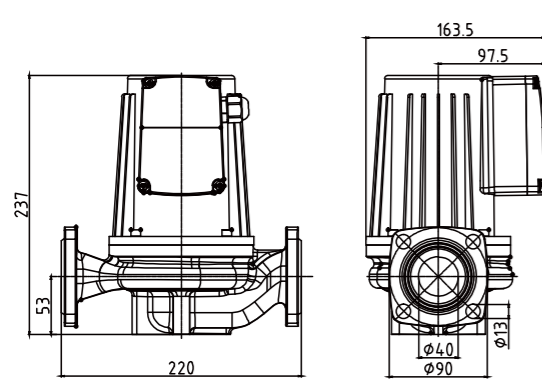

GRS32/12F-M

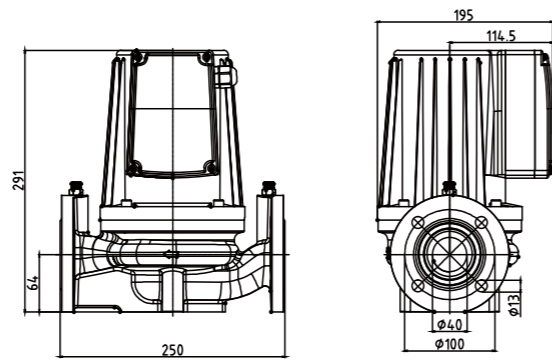

GRS40/17F-M/GRS40/19F-M

Model (single phase)	Power (w)	Max Flow Rate (l/min)	Max Head (m)	Inlet/Outlet
GRS32/12F-M	370	135	12	DN40
GRS40/14F-M	550	165	14	DN40
GRS40/17F-M	700	170	17	DN40
GRS40/19F-M	900	170	19	DN40
GRS50/15F-M	1100	370	15	DN50

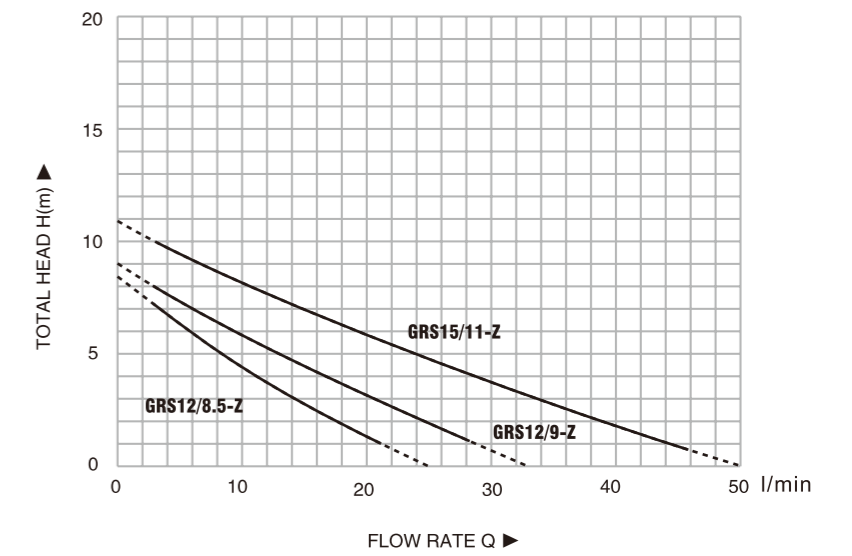
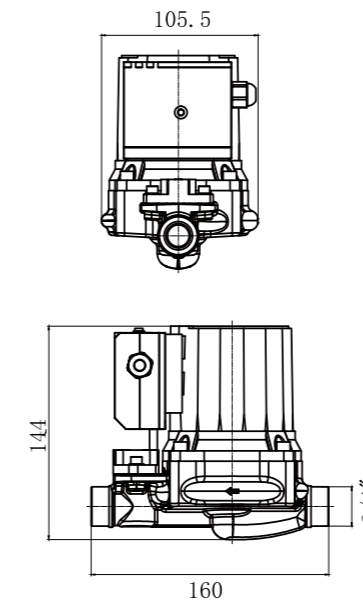

Model	Power (w)	Max Flow Rate (l/min)	Max Head (m)	Inlet/Outlet (In)
GRS12/8.5-Z	100	25	8.5	3/4"x3/4"
GRS12/9-Z	120	33	9	3/4"x3/4"
GRS15/11-Z	200	50	11	1"x1"

CL BOOSTER PUMP



(HOT WATER)

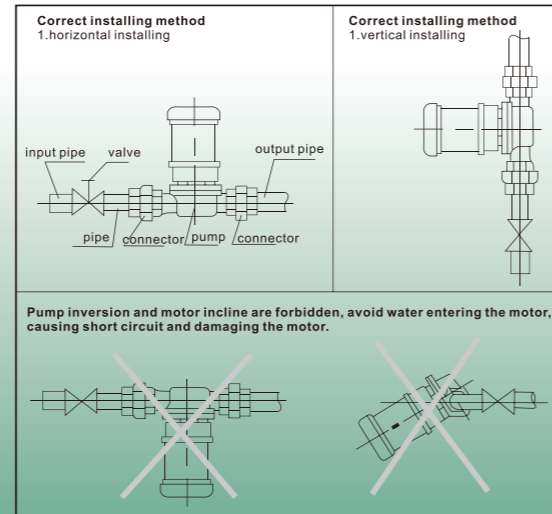

Barss

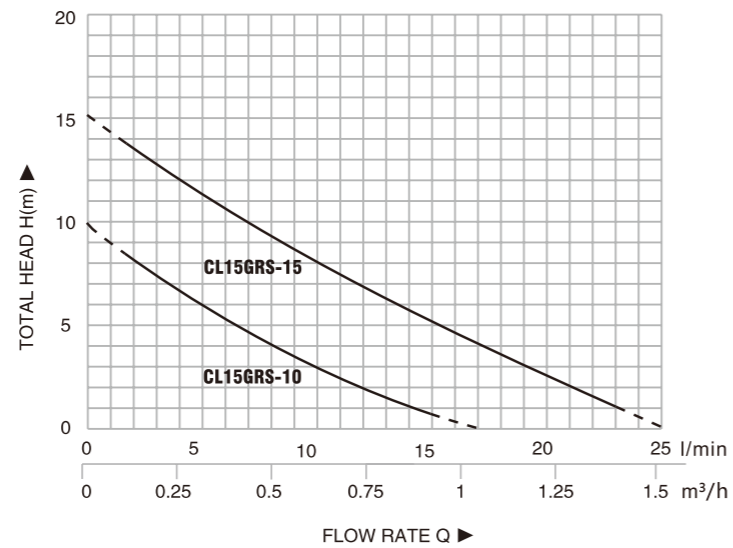

Model	Max.Input Power (w)	Output Power (w)	Max.Flow (l/min)	Max.Head (m)	Inlet/Outlet (In)
CL15GRS-10	130	90	13	10	0.75"X0.75"
CL15GRS-15	230	120	25	15	0.75"X0.75"

STRUCTURE CHART

STAR-A

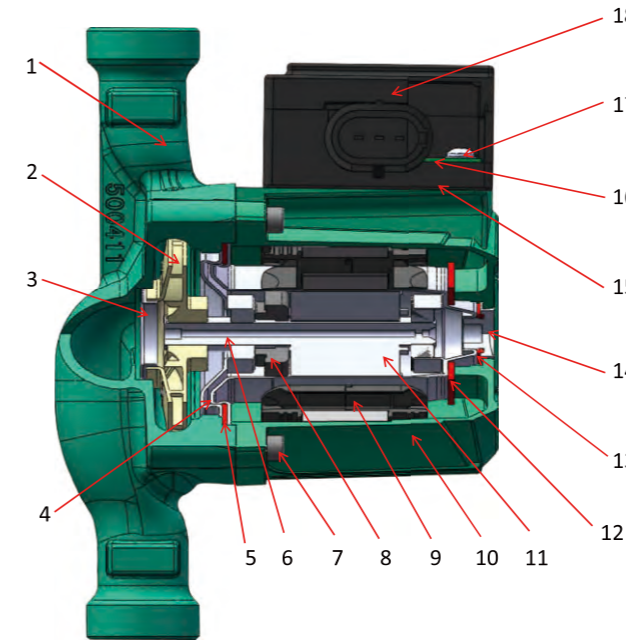

- 1.Pump body
- 2.Impeller
- 3.Thimble
- 4.Shielding
- 5.O-ring
- 6.Shaft
- 7.Screw
- 8.Graphite static ring
- 9.Stator
- 10.Motor body
- 11.Rotor
- 12.Seal washer
- 13.O-ring
- 14.Bolt
- 15.Terminal box
- 16.Energy saving circuit board
- 17.Cross pan head
- 18.Terminal box cover

GRS

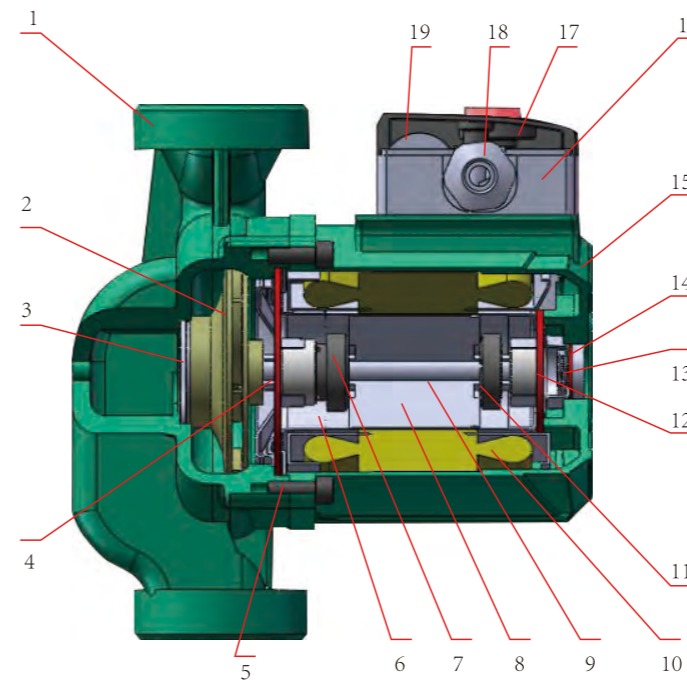

- 1.Pump body
- 2.Impeller
- 3.Thimble
- 4.O-ring
- 5.Bolt
- 6.Shielding
- 7.Graphite static ring
- 8.Rotor
- 9.Shaft
- 10.Stator
- 11.Graphite static ring
- 12.Seal washer
- 13.O-ring
- 14.Bolt
- 15.Motor body
- 16.Terminal box
- 17.Terminal cover
- 18.Cable protector
- 19.Capacitor

BOILER PUMP

Introduction

UPSP series pumps are suitable for the gas (electric) wall hanging furnace heating system. The pump can run in the heating circulation pipeline at the speed of three gear. The circulating water will produce oxygen, nitrogen and so on in the process of repeated heating cycle. The existence of these gases will aggravate the corrosion of the system pipe and form gas plugging to reduce heating effect. A lot of energy is wasted, or the phenomenon of vortex cavitation occurs, which makes the running noise of the pump increase. The self placed exhaust valve in the UPSP pump can quickly discharge the liquid entrainment of the pipe. At the same time, when the system produces negative pressure, the water surface of the exhaust valve cavity falls, the exhaust valve opens, and the air passes through the vent to prevent the negative pressure from the harm.

Product Feature

1. Wall hung gas boiler pump is composed of stator, rotor, shield cover, pump body, vent valve and so on.
2. Sealing: stator and rotor sealed up with stainless steel shield cover, integral structure sealed up with heat-resisting rubber washer, rather than mechanical seal. This ensures no leakage.
3. Lubrication and cooling: use internal circulation, lubricated and cooled by circulated liquid.
4. Motor: Insulation Class is H. Motor has two series of permanent magnet and three speed control.
5. Protection Class: IP 42.
6. Noise: The noise of pump that works in a boiler with rated flow is less than 42 dB(A).

Automatic exhaust

The TAIFU UPSP series pump is a water pump with built-in automatic air separator that discharges air from the system. The air-containing liquid is guided from the inlet to the nozzle of the air separation chamber. The decelerated liquid at this time will jointly drive the air to separate from the liquid, and the air will escape the pump through the automatic exhaust valve of the air separation chamber.

(Note: The air separator water pump is only suitable for upward water flow).

UPSP series performance curve and technical parameters

The pump is an AC efficient circulating pump and the pump motor has 2 poles.

On the basis of UPS optimization and upgrading, the pump saves about 20% energy compared with the same specifications of AC pumps.

The performance curve test conditions are as follows

1. Test clean water without air.
2. Test water temperature (20°C–25°C)
3. All curves show averages. However, it cannot be used as a security curve. For specific curve performance, a separate test must be performed.
4. TAIFU UPSP series pump curve is suitable for liquids with kinematic viscosity $\nu=1\text{mm}^2/\text{S}$ (1cst) .

Water pump model identification

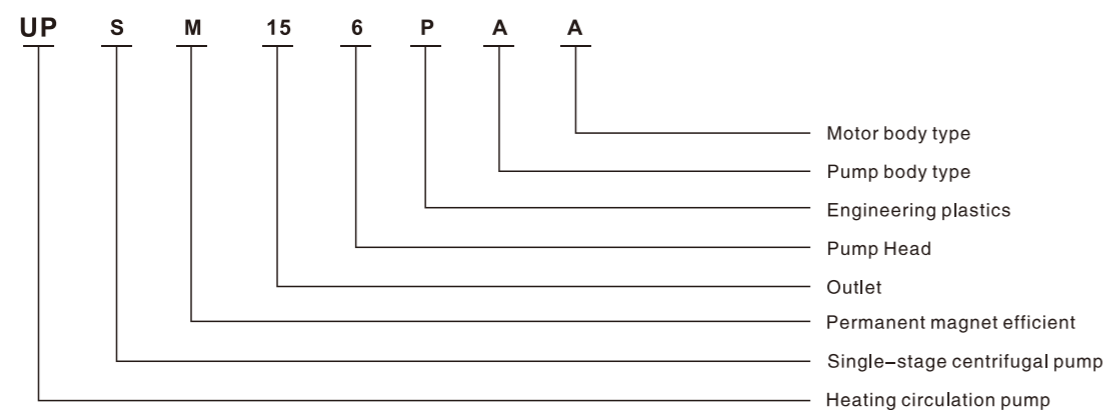

UPSP-A BOILER PUMP

Two types of pump body for selection

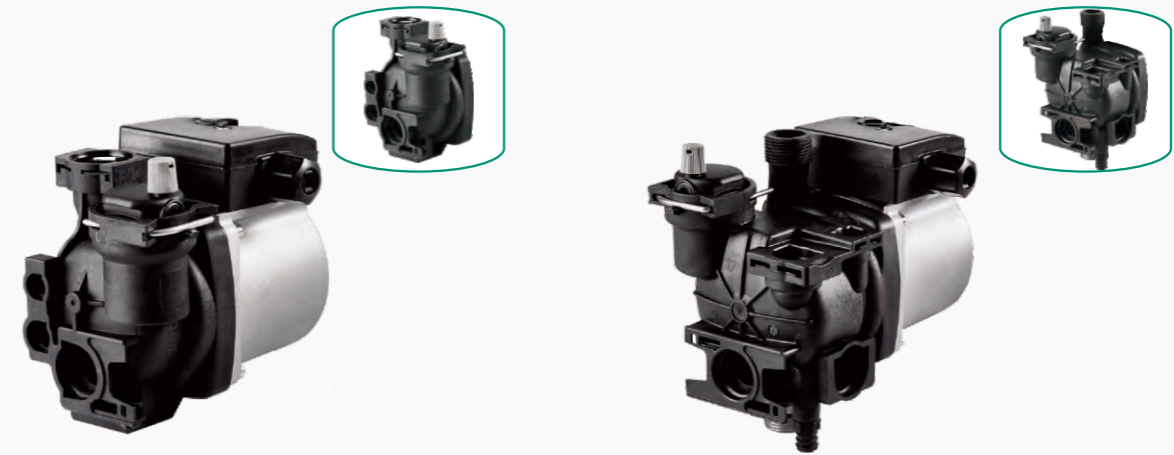

UPS15-5PA/A

UPS15-5PB/A

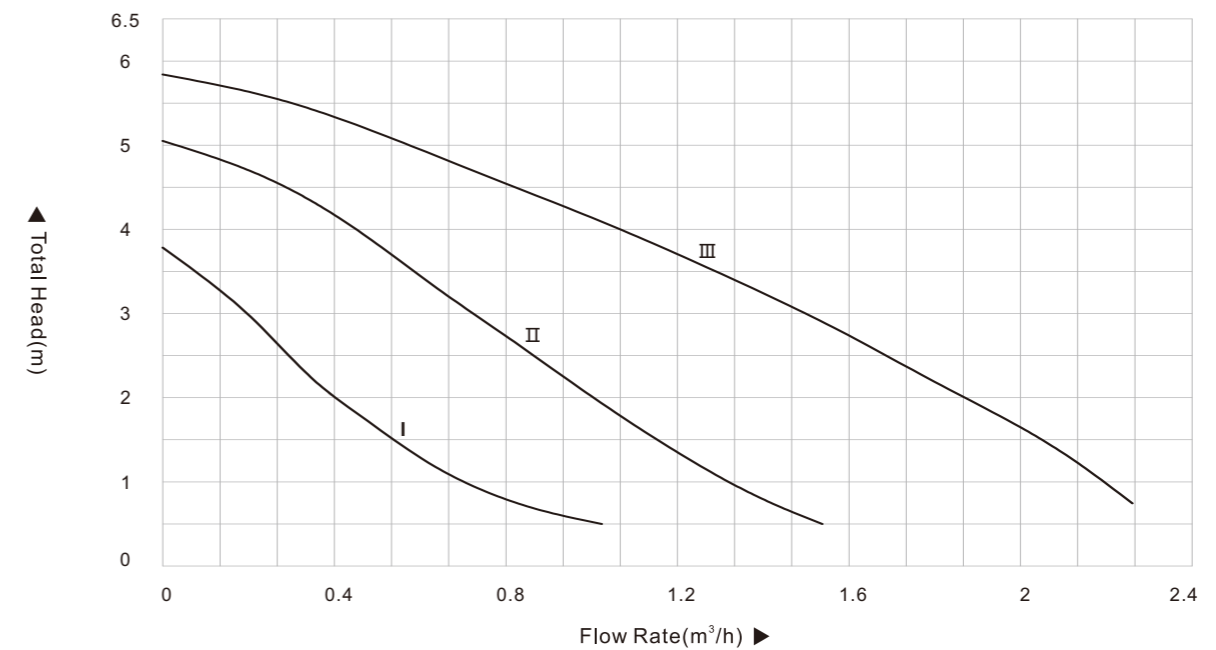

Model	Input Power (V/Hz)	Max Power (W)	Max Flow Rate (l/min)	Max Head (m)	Temperature (°C)	Water Pressure (bar)	Outlet (In)
UPS15-5PA(B)/A	220/50	90	36	5	0-95	3	3/4"
UPS15-6PA(B)/A	220/50	95	38	6	0-95	3	3/4"

UPSP-B BOILER PUMP

Two types of pump body for selection



UPS15-6PA/B

UPS15-6PB/B

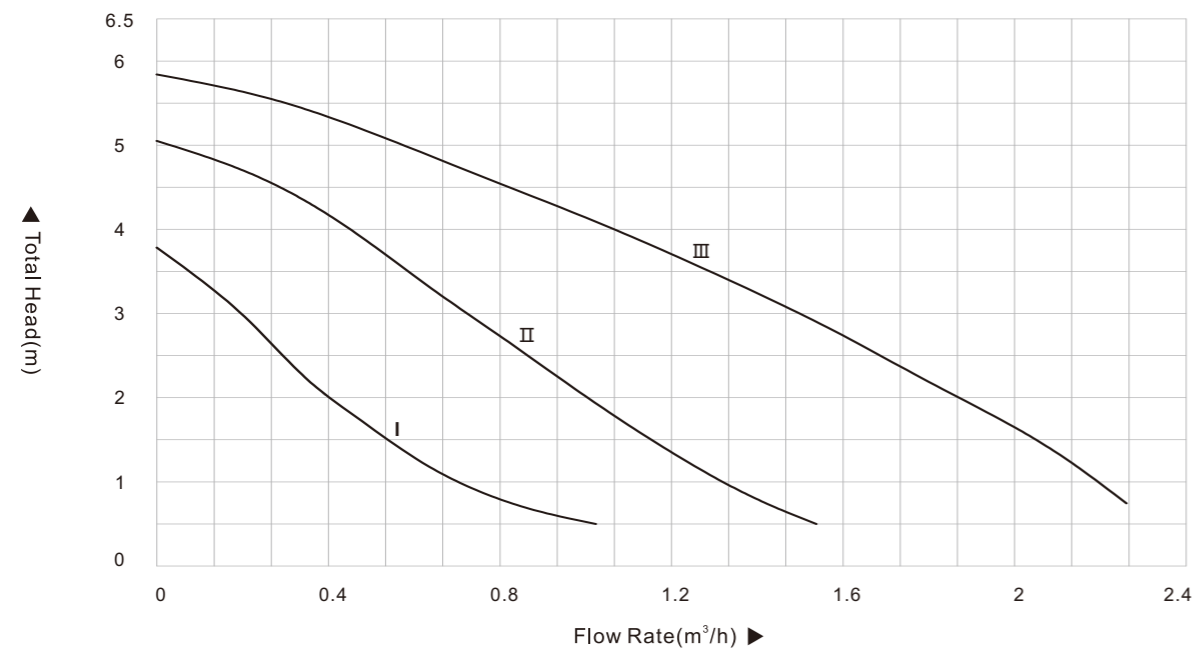

Model	Input Power (V/Hz)	Max Power (W)	Max Flow Rate (l/min)	Max Head (m)	Temperature (°C)	Water Pressure (bar)	Outlet (In)
UPS15-5PA(B)/B	220/50	90	36	5	0~95	3	3/4"
UPS15-6PA(B)/B	220/50	95	38	6	0~95	3	3/4"

UPMP-A BOILER PUMP

Two types of pump body for selection



UPM15-6PA/A

UPM15-6PB/A

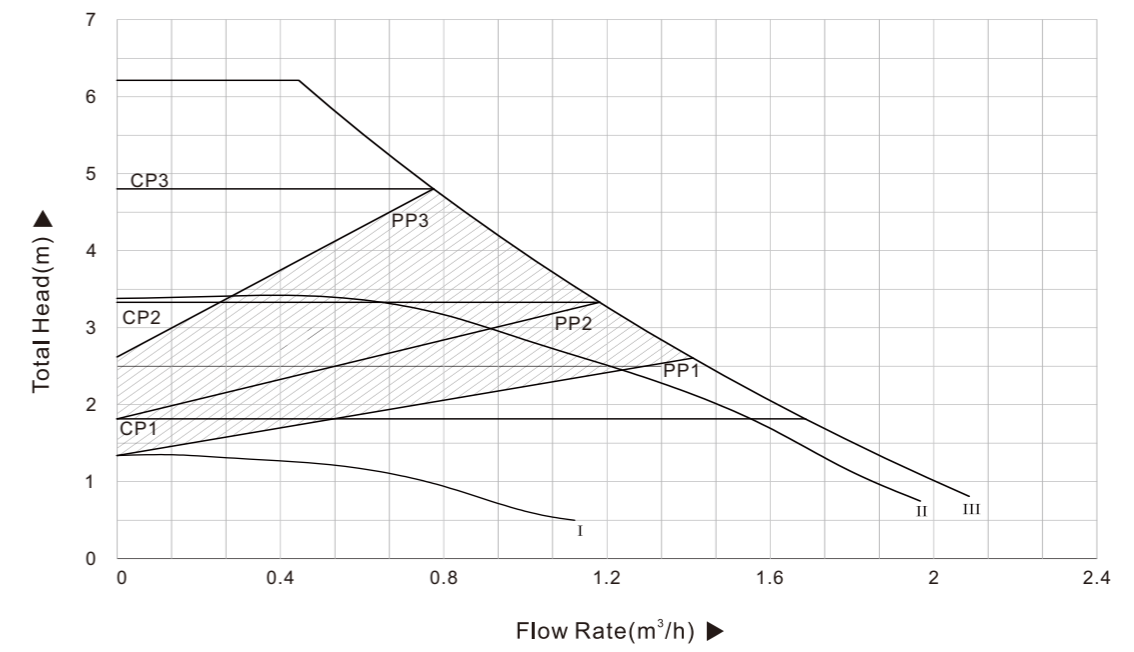

Model	Input Power (V/Hz)	Max Power (W)	Max Flow Rate (l/min)	Max Head (m)	Temperature (°C)	Water Pressure (bar)	Outlet (In)
UPM15-5PA(B)/A	220/50	45	36	5	0~95	3	3/4"
UPM15-6PA(B)/A	220/50	45	38	6	0~95	3	3/4"